

WOODWORKER'S JOURNAL

downloadable plans:
"America's leading woodworking authority"™

In this plan you will be getting:

- Step by Step construction instruction.
- A complete bill of materials.
- Exploded view and elevation drawings.
- How-to photos with instructive captions.
- Tips to help you complete the project and become a better woodworker.

 To download these plans, you will need **Adobe Reader** installed on your computer. If you want to get a free copy, you can get it at: **Adobe Reader**.

Having trouble downloading the plans?

- If you're using Microsoft Internet Explorer, right click on the download link and select "Save Target As" to download to your local drive.
- If you're using Netscape, right click on the download link and select "Save Link As" to download to your local drive.

WOODWORKER'S JOURNAL
©2007 ALL RIGHTS RESERVED



This plan brought to you by:

Stickley Leather-top Desk



Published in **Woodworker's Journal** "From Shop to Home: Essential Projects, Tips and Techniques for Today's Home Woodworker"

A Stickley-inspired Leather-top Desk

Without sacrificing any of the charm or structural integrity of our Stickley-inspired design, modern methods and materials bring this white oak desk within the reach of almost any woodworker's skills.



Sometimes, building a beautiful, practical piece of furniture can remind you of all the reasons you started woodworking in the first place. Such was the case for Brad Becker, the original builder of this Stickley-inspired oak desk. His sentiments rang true for other readers as well, making this project one of the more popular Arts & Crafts pieces we've published in the past ten years or so.

The desk is a series of simple frame and panel subassemblies joined with modern biscuits, hidden screws and glue. Brad designed the desk with basic joinery so that anyone with a little experience, a good router and a table saw will have no problem building it.

Starting with the Back

The back of the desk is made up of two rails, two stiles and three panels (pieces 1 through 4). Cut these and all the other parts to the dimensions shown in the *Material List* on page 97. With any project, measuring and test fitting each part as you make it is wise. The cabinet shop proverb — measure twice, cut once — holds true for all

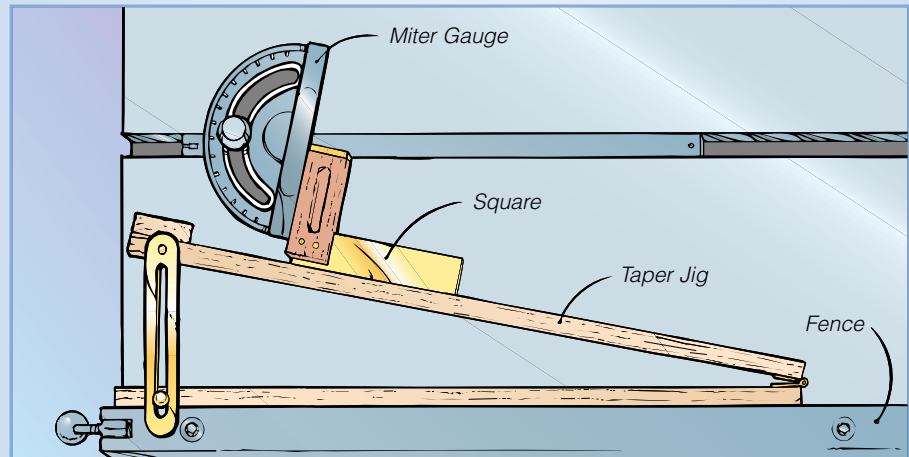

Figure 1: Tapering the outside faces of the legs adds an element of style to their blocky, rectangular shapes.

Quick Tip

Taper Jig Set-up

Setting a taper jig to the correct angle is a snap if you use your table saw miter gauge and a square. Slide the miter gauge into a table saw slot and set the gauge to the angle you want for the taper jig. Now slide the saw fence and taper jig over to the miter gauge and use the square to position the jig at the angle you need.



woodworking. Chuck a $\frac{1}{4}$ " bit in your table-mounted router, set the fence, and mill $\frac{1}{2}$ " deep grooves in both edges of both stiles, plus the appropriate edges of the top and bottom rails. (All dimensions are on the *Elevations* and *Exploded Drawings* on the next two pages.) The groove cuts should be made in several passes, raising the bit about $\frac{1}{8}$ " each time to avoid tearout and excessive wear on the router.

These stiles and rails have $\frac{1}{4}$ " wide tenons centered on their ends. Form them using a fine cross-cut blade in the table saw coupled with the saw's miter gauge and nibble away the waste in successive cuts.

The tenons at each end of the bot-

This project uses simple joinery and modern materials, like this white oak veneer plywood, to create an authentic Arts & Crafts appearance.



Desk Elevation
(Front View)

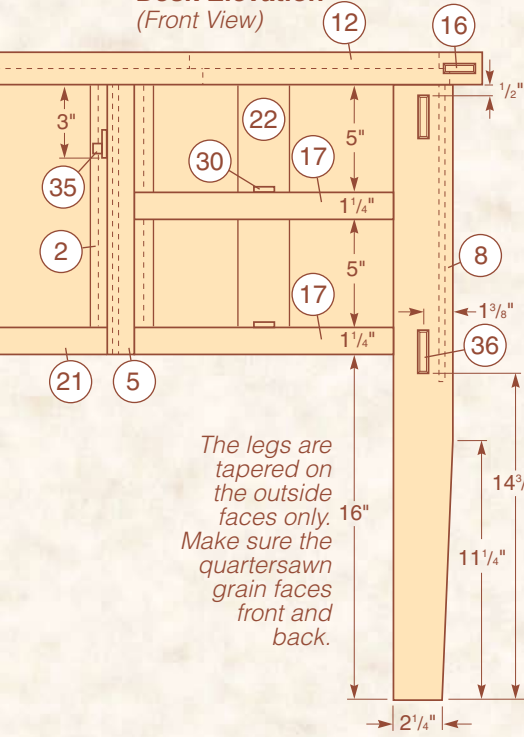

The legs are tapered on the outside faces only. Make sure the quartersawn grain faces front and back.

Leg Joinery Detail
(Top View)

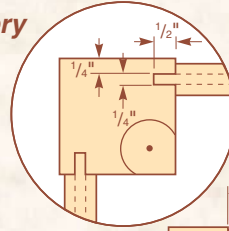

NOTE: The tabletop fasteners are located on the top of each leg.

Desk Elevation
(Top View)

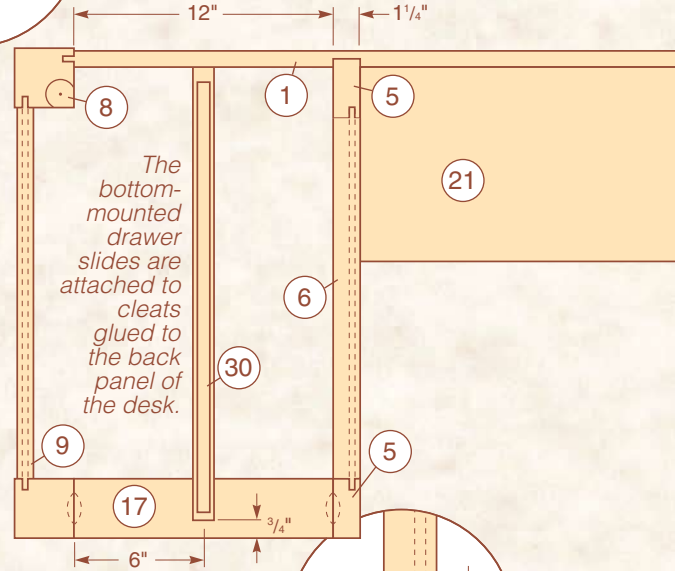

The bottom-mounted drawer slides are attached to cleats glued to the back panel of the desk.

Faux Tenon
(Side View) (End View)

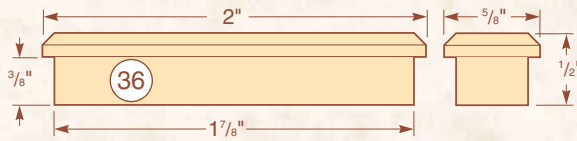
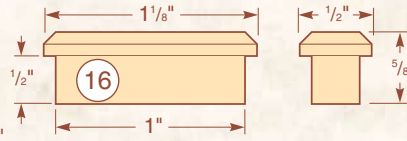

Leg Faux Tenon (Side View) (End View)

Biscuit and Frame Joinery Detail
(Top View)

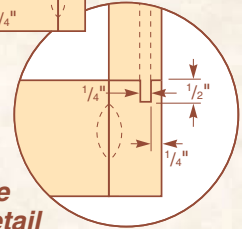

Desk Elevation
(Side View)

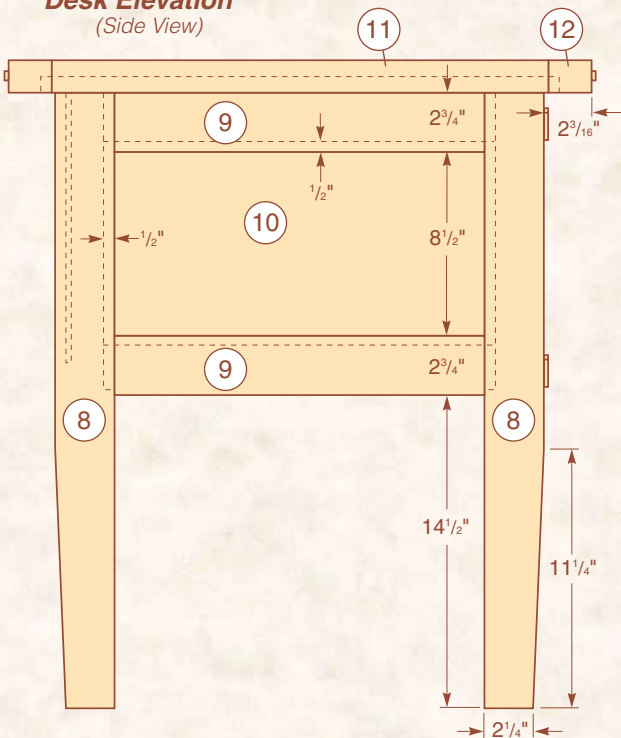

Desk Elevation
(Back View)

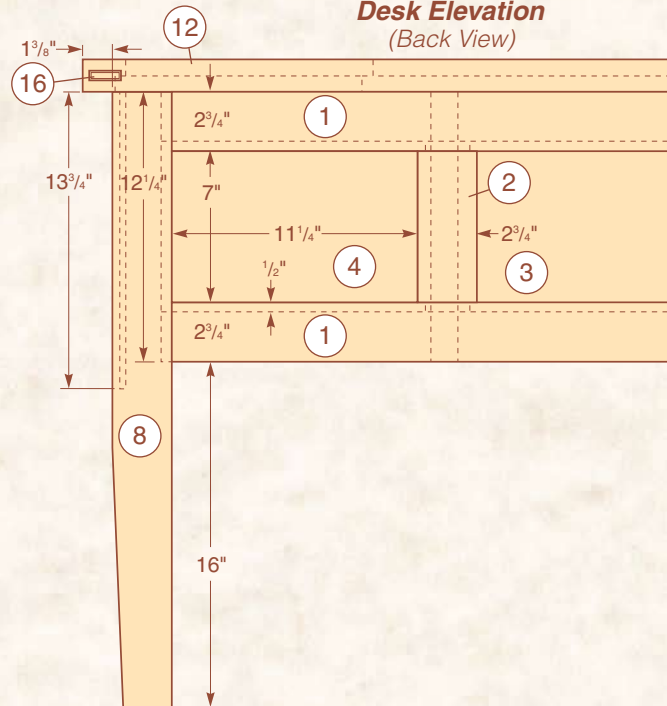

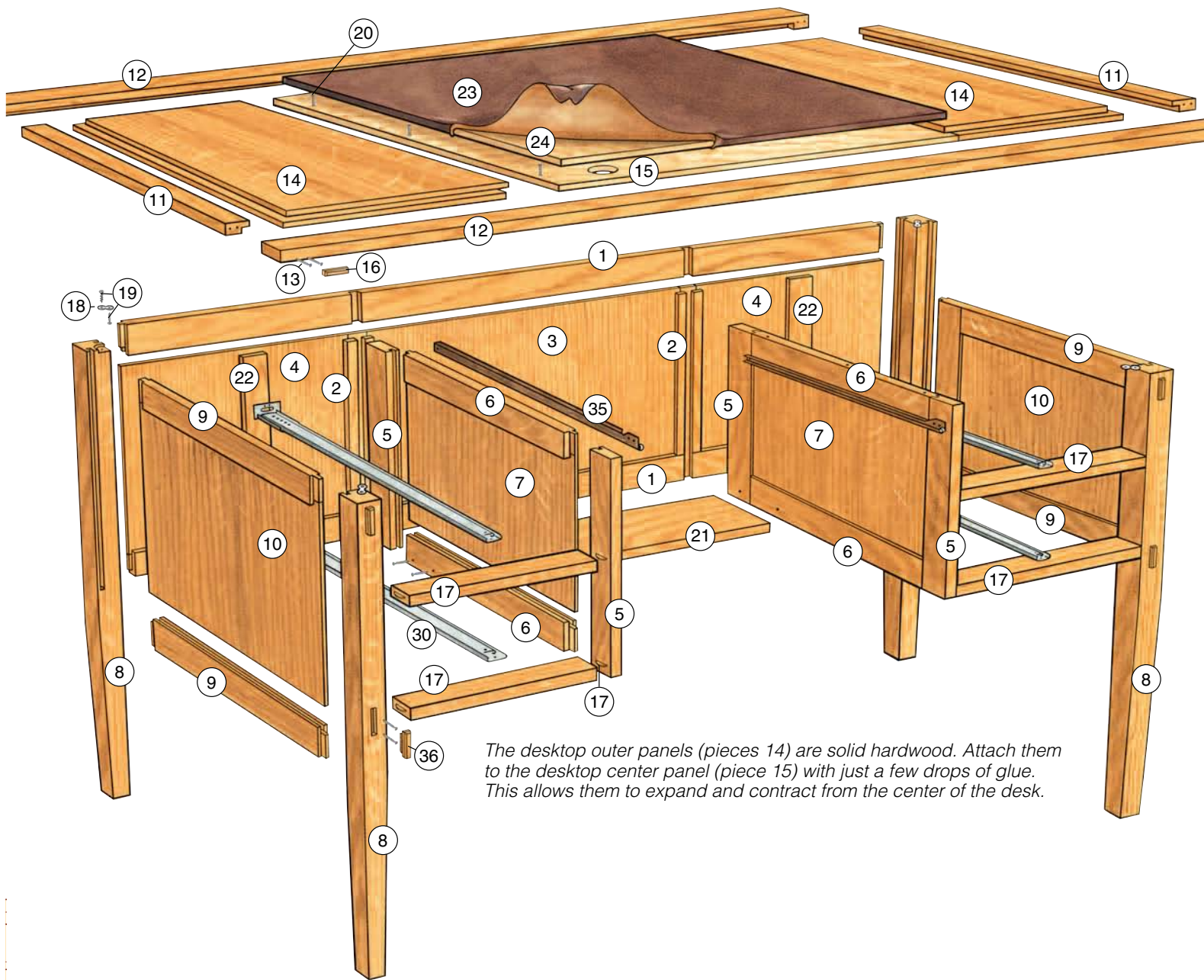

The desktop outer panels (pieces 14) are solid hardwood. Attach them to the desktop center panel (piece 15) with just a few drops of glue. This allows them to expand and contract from the center of the desk.

MATERIAL LIST

	T x W x L
1 Back Frame Rails (2)	3/4" x 2 3/4" x 49 1/4"
2 Back Frame Stiles (2)	3/4" x 2 3/4" x 8"
3 Back Frame Center Panel (1)	1/4" x 21" x 8"
4 Back Frame Side Panels (2)	1/4" x 12 3/8" x 8"
5 Interior Frame Stiles (4)	1 1/4" x 2 3/4" x 12 1/2"
6 Interior Frame Rails (4)	1 1/4" x 2 3/4" x 17 1/2"
7 Interior Frame Panels (2)	1/4" x 17 1/2" x 8"
8 Legs (4)	2 3/4" x 2 3/4" x 28 1/2"
9 Exterior Frame Rails (4)	3/4" x 2 3/4" x 18 1/8"
10 Exterior Frame Panels (2)	1/4" x 18 1/8" x 9 1/2"
11 Desktop Sides (2)	1 1/2" x 2" x 23"
12 Desktop Front & Back (2)	1 1/2" x 2" x 56 1/2"

	T x W x L
13 Large Screws (12)	#10 x 3"
14 Desktop Outer Panels (2)	1 1/2" x 12" x 24"
15 Desktop Center Panel (1)	3/4" x 24" x 30 1/2"
16 Top Faux Tenons (4)	1/2" x 1 1/8" x 5/8"
17 Drawer Dividers (4)	1 1/4" x 2 3/4" x 12"
18 Tabletop Fasteners (4)	Steel
19 Tabletop Fastener Screws (8)	Steel
20 Tabletop Screws (12)	#8 x 2"
21 Leg Space Shelf (1)	1 1/4" x 9" x 21 3/4"
22 Drawer Cleats (2)	1/4" x 3" x 7"
23 Leather (1)	25" x 31"
24 Leather Backer (1)	3/4" x 29 1/2" x 23"

Quick Tip

Joining Boards Without a Jointer

By coupling a straight edge with end clamps and a pattern-cutting router bit, you can easily join boards. Mount the bit in your router table. Adjust the bit so the height equals the thickness of the board plus the bearing thickness, then clamp the edge guide along the edge you want to cut. Pass the board along the router bit with the bearing running along the edge guide. You can also use this guide/pattern bit combination for other operations, such as trimming down doors to fit.

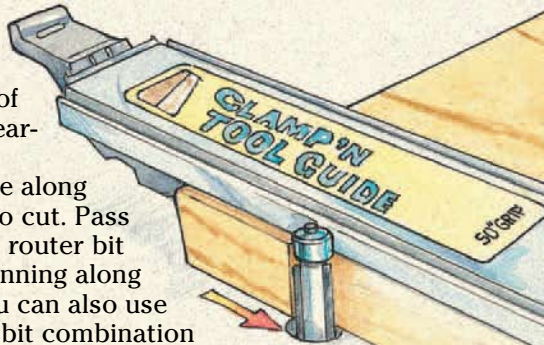

tom rail are notched $\frac{1}{4}$ " from the bottom. These cuts can be made on a bandsaw or with a sharp backsaw. With that done, you're ready to dry fit the frame together and check your joinery. When you're pleased with the fit, apply glue to the stile and rail joints (but not the plywood panels, as they need to float freely). Make sure the subassembly is flat and square as you clamp it up.

After the glue cures, use a router and straight-edge to plow a vertical $\frac{1}{4}$ " deep groove on the inside face of the stiles. These grooves are $1\frac{1}{4}$ " wide and will be used to join the interior frames to the back.

Building the Interior Frames

The interior frame subassemblies house the

drawers and surround the desk owner's legs. Begin machining them at the router table by plowing a $\frac{1}{2}$ " deep groove in each stile (pieces 5) and rail (pieces 6) at the locations shown on the *Elevation Drawings*. Then move to the table saw to mill tenons on the ends of each rail. These are relatively simple cuts as no shoulder is required.



Figure 2:

Assemble the desktop frame and cut a rabbet in its bottom edge with a bearing-guided bit. Square the corners with a sharp chisel.

Glue and clamp the two subassemblies together, again letting the panels (pieces 7) float freely in the frames.

Machining the Legs

Use either solid or glued-up stock to make blanks for the legs (pieces 8). Either way, have the quartersawn grain showing on the front and back faces of each. After cutting the legs to size, taper their two outside faces, as shown in *Figure 1*. Use

WOODWORKER'S GLOSSARY

Arts & Crafts:

A design style originated in the mid-1800s by William Morris to offset the elaborate detailing of the Victorian styles. Its purpose was to show a simple handcrafted artist's approach to furniture design. The popular Mission furniture is a variation of this style.

Figure 3: Before final assembly, test fit the joints between pre-made subassemblies, such as the back sub-assembly and the legs.



a tapering jig and great care to slice the angles off the legs (see *Desk Elevation Front and Side Views* for taper dimensions).

Move back to the router table to mill the 1/2" deep stopped grooves in each leg to accommodate the sides and back. Stopping the grooves in the right spot is simply a matter of matching up pencil marks on the leg and the router table fence. Wrap up the legs by using a router equipped with a 1/4" straight bit to create the small mortises for the legs' decorative faux tenons (see the *sidebar* on this page).

Building the Exterior Frames

Cut and mill the four rails for the exterior frames (pieces 9), using the same techniques as you did for the interior frame rails; just notice that the lengths are different. Notch the tenons on the two bottom rails (see the *Elevation Drawings*) to create 1/4" shoulders.

Test the tenons' fit in the legs, then cut the panels (pieces 10) to size. Glue and clamp the rails to the legs while slipping the panels in place without glue.

Building the Top

Begin making the top by creating a simple, butt-jointed frame with the front, back and sides (pieces 11 and 12). Start by cutting the parts to size, then chop the small, shallow mortises for the faux tenons and screws on the long frame pieces. Pre-drill each piece to properly accept the screws (pieces 13), then assemble the frame without glue. Turn the frame upside down and, using a bearing-guided rabbeting bit, mill a rabbet around the inside edge (see *Figure 2*). Square the corners with a sharp chisel after you're done routing the rabbeted edge.

Select solid hardwood stock with beautiful grain and figure for the two outer desktop panels (pieces 14). Form rabbets on the edges of each

panel. (Note that on three sides, this rabbet is milled on the top face while on the fourth side it is milled on the bottom face.) Cut the center panel (piece 15) from 3/4" plywood and, after predrilling screw holes, attach it to the frame with screws only. Test fit the two outer panels to the center panel and frame. When all the parts fit together well, remove the screws and reassemble the top with glue and screws. Apply a couple drops of glue to the joint between the center panel and the inverted rabbet on the outer panels. This will ensure both panels will expand and contract out from the center of the desk. Finally, glue the top faux tenons (pieces 16) in place.

Assembling the Desk

Sand the subassemblies down through the grits to 220, and test fit all your joints (see *Figure 3*). Then lay out and mill the eight biscuit slots for the drawer dividers (pieces 17). Glue and clamp the two interior frames in their dadoes in the back, then glue the subassembly into the stopped grooves in the legs (don't glue the panels in place during this process). Before this glue begins to set, install the drawer dividers with glue and biscuits. Make sure everything is square as you tighten the clamps. Once the glue dries, use a Forstner bit to create round mor-

There are two different size faux tenons on this desk. The top frame set have larger tails and cover a set of screws. The leg set are machined with tiny tenoned tails to glue into 1/4" mortises. They're easy to make and ensure a clean attractive look.

Machine the faux tenons in three steps: Chamfer the ends and edges of your stock on a sander, relieve the tenon tails on your table saw, and slice them free with a bandsaw and miter gauge.



Be sure to make each size faux tenon in sets. Use a registration block clamped to your miter gauge to ensure uniformity.

Finisher's Scorecard:

Choosing the best finish for your project doesn't have to be difficult if you know the basic characteristics of these eight common finishes. Incidentally, chatoyance refers to the ability of the finish to enhance depth and figure, "popping" the grain.

- Wax** – thin; apply by rag; easy to repair; poor chatoyance; sheds water but takes water marks; poor solvent, scratch and heat resistance; fair stain resistance.
- Oil and Danish oil** – thin; apply by rag; easy to repair; good chatoyance; good water, heat, and solvent resistance; poor scratch resistance; fair stain resistance.
- Shellac** – apply thin or thick by rag, brush or spray; easy to repair; good chatoyance; poor heat and alkali resistance; good water and scratch resistance; fair solvent resistance; good stain and acid resistance.
- Lacquer** – apply thin or thick by brush or spray; easy to repair; good chatoyance; poor to fair heat resistance; good water, scratch, stain and solvent resistance.
- Oil varnish** – apply thin or thick by rag, brush or spray; not easy to repair; good chatoyance; good water, heat, solvent, scratch and stain resistance (if thick).
- Polyurethane (oil base)** – apply thin or thick by rag, brush or spray; not easy to repair; good chatoyance; good water and stain resistance; excellent solvent, heat, and scratch resistance.
- Waterborne acrylic-polyurethane** – apply thin or thick by pad, brush or spray; moderately easy to repair; poor chatoyance; good water, stain, solvent, heat, and scratch resistance.
- Two part coatings (catalyzed lacquer, conversion varnish, automotive polyurethane)** – apply thick by spray; very difficult to repair; excellent water, stain, solvent, heat and scratch resistance; chatoyance varies.

tises in the tops of the legs (see *Leg Joinery Detail*, page 96), then secure the tabletop fasteners (pieces 18) to the legs with screws (pieces 19).

To join the top and bottom subassemblies, start by placing the desktop on the lower desk assembly. From the underside, mark where the interior frames touch the desktop's center panel. Remove the top and drill pilot holes for screwing through the top into the interior frames, countersinking the holes from the upper face. Center the top on the desk body, then drive your screws (pieces 20) down through the center panel into your predrilled pilot holes in the interior frame's top rails (pieces 6). Finish securing the frame in place by driving screws (pieces 19) up through the tabletop fasteners into predrilled pilot holes in its bottom face, then attach the leg space shelf (piece 21) with screws (pieces 13). Take a moment to glue the drawer cleats (pieces 22) to the plywood

Quick Tip

Yet Another Way to Use 3M's All Purpose Post-it™ Notes

Marking the spot to drill for hardware on a freshly finished piece can be trying. Next time you are confronted with this dilemma try placing a Post-it™ Note in the approximate location of the intended hole and make your marks on it instead.

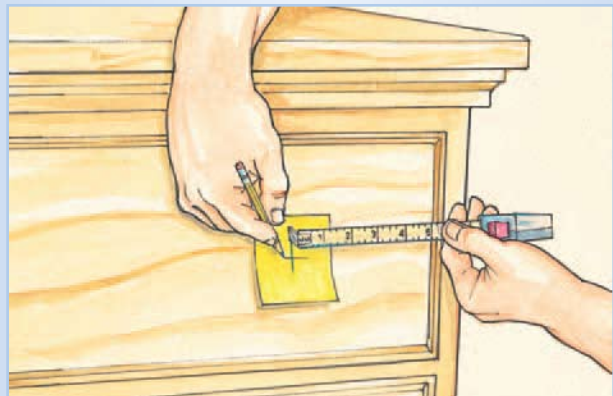

CORNER LOCKING DRAWER JOINERY

A small $\frac{1}{4}$ " x $1\frac{1}{2}$ " notch allows the drawer slides to clear the front and back of the deep drawers.

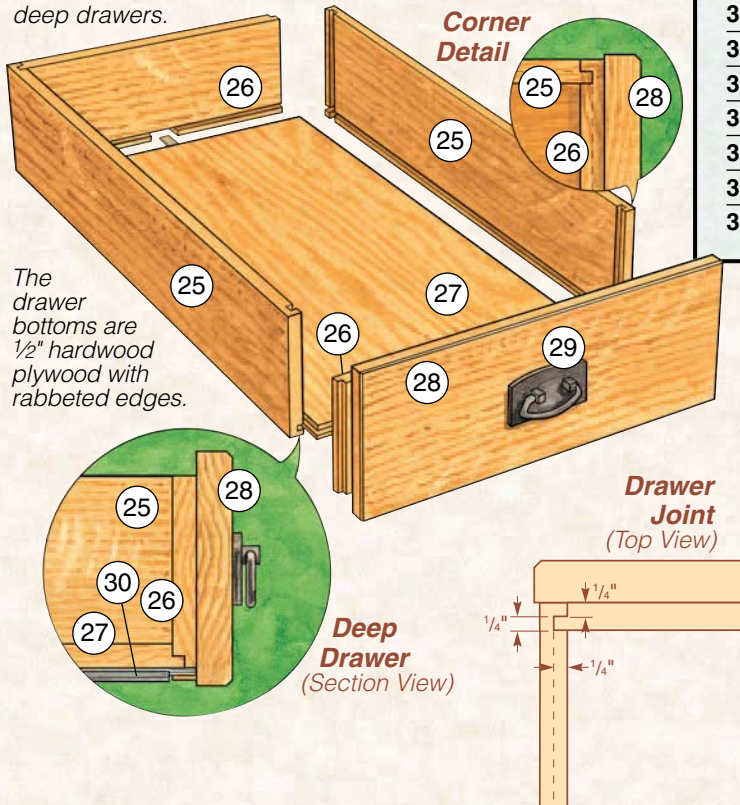
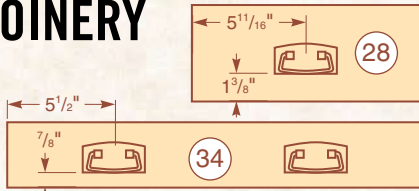

The drawer bottoms are $\frac{1}{2}$ " hardwood plywood with rabbeted edges.

MATERIAL LIST (DRAWERS)

	T x W x L
25 Deep Drawer Sides (8)	$\frac{1}{2}$ " x $4\frac{1}{4}$ " x $19\frac{3}{4}$ "
26 Deep Drawer Fronts & Backs (8)	$\frac{1}{2}$ " x $4\frac{1}{4}$ " x $10\frac{3}{4}$ "
27 Deep Drawer Bottoms (4)	$\frac{1}{2}$ " x $10\frac{3}{4}$ " x $19\frac{1}{8}$ "
28 Deep Drawer Faces (4)	$\frac{3}{4}$ " x $4\frac{7}{8}$ " x $11\frac{7}{8}$ "
29 Drawer Pulls (6)	Mission style
30 Deep Drawer Slides (4)	21"
31 Pencil Drawer Sides (2)	$\frac{1}{2}$ " x $2\frac{1}{2}$ " x 18"
32 Pencil Drawer Front & Back (2)	$\frac{1}{2}$ " x $2\frac{1}{2}$ " x $20\frac{1}{4}$ "
33 Pencil Drawer Bottom (1)	$\frac{1}{2}$ " x $20\frac{1}{4}$ " x $17\frac{1}{2}$ "
34 Pencil Drawer Face (1)	$\frac{3}{4}$ " x $3\frac{1}{4}$ " x $21\frac{5}{8}$ "
35 Pencil Drawer Slides (1 pair)	18"
36 Faux Tenons (4)	$\frac{5}{8}$ " x 2" x $\frac{1}{2}$ "

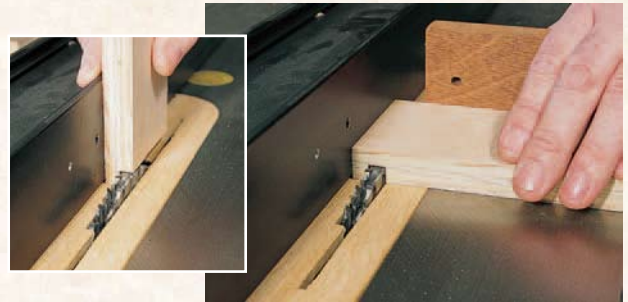

The drawer fronts and backs are rabbeted on their ends (left inset). Drawer sides (above right) have $\frac{1}{4}$ " dados milled across their ends. Both steps can be done on the same setup, as shown above. The $\frac{1}{4}$ " drawer bottom grooves are also formed on the same table saw setup.

panels inside the drawer cavity (refer to the *Elevation Drawings* on page 96).

Drill a finger hole in the top's center panel to help lift the removable leather covered panel, then cut the leather (piece 23) and its backer (piece 24) to shape and dry-fit them to the top of the desk. When the fit is right, glue the leather to the backer with 3M's 77 spray adhesive.

Making the Drawers

Refer to the illustrations and photos on this page to mill the joinery on the sides, fronts and backs of the four deep drawers and the shallow pencil drawer (pieces 25 through 35). Assemble each box and sand smooth. Cut the drawer faces from attractive hardwood stock. Mount the drawer pulls with their bolt heads counterbored into

the back of the drawer faces.

With the drawer boxes complete, install the drawer slides according to the manufacturer's instructions, then slide the drawers into their openings. Use double-sided tape to temporarily position and mark the locations of the drawer faces, then screw the faces in place. Install the remaining faux tenons. Remove the drawer faces and hardware for finishing.

Wrap up this project by applying a light walnut oil stain, topped by at least three coats of clear matte lacquer. Sand between these coats with 400-grit paper. Reinstall the drawer faces and drawer pulls after the finish dries.